

# Polytuf Tarps

# SUPERWHITE GROMMETED TARPS

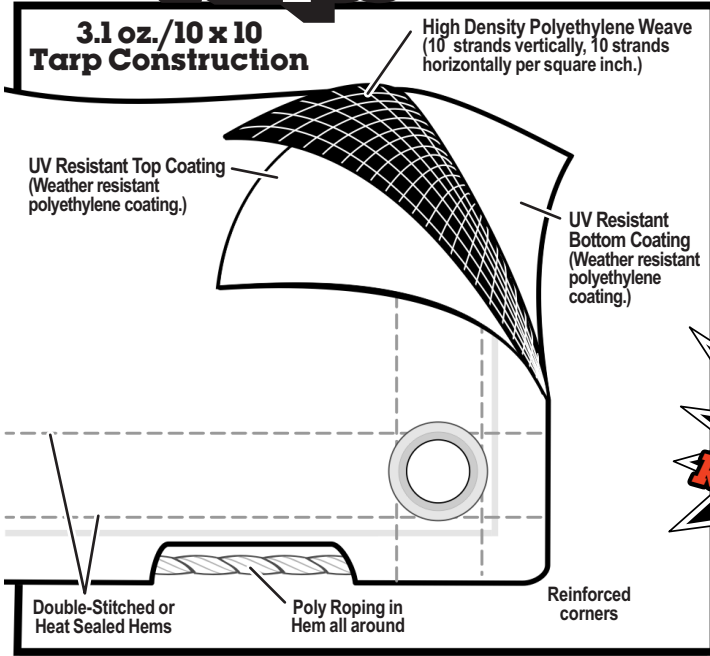

**The Lightweight, Durable Tarp and Translucent Barrier!**

## CONSTRUCTION FEATURES

• 3.1 ounce per square yard • 10x10 sq. in count • UV Resistant • Heat sealed seams • 3/16" boltroping in hem • Aluminum rustproof grommets about every three feet around the hem • 7-8 mil thickness • UPC coded • White both sides

## STRENGTH AND DURABILITY

Polytuf's SUPERWHITE Tarp is the ideal high volume tarp. Its signature white color instantly identifies it's strength and value to the consumer. SUPERWHITE is the preferred choice because of its low cost and convenience. UV resistant top and bottom coating. Our tough SUPERWHITE Tarps come in a wide range of sizes to suit both your contractor's needs.

Distributed by: \_\_\_\_\_

- Tough, HDPE Woven Fabric
- Lightweight, yet Heavy Duty
- UVI Treated for Extra Life
- Easily Secured - Grommets in Each Corner and About Every 3 Feet All Around Hem
- Rugged - Poly Roping Inside Hem for Added



<b>FULL FINISHED SIZE</b>	<b>TARPS/CARTON</b>	<b>MODEL #</b>
<b>8'x10'</b>	8	WU8x10P
<b>10'x12'</b>	6	WU9x12P
<b>10'x20'</b>	6	WU10x20P
<b>12'x20'</b>	10	WU12x20P
<b>12'x25'</b>	8	WU12x25P
<b>15'x25'</b>	6	WU15x25P
<b>15'x30'</b>	6	WU15x30P
<b>20'x20'</b>	6	WU20x20P
<b>20'x40'</b>	3	WU20x40P

Meets the flammability requirements of Commercial Standard CS-192-53 (Paragraph 410) for General Purpose Vinyl Plastic Film, to which the Flammable Fabrics Act, Public Law 88 refer. However, **NOT SOLD OR INTENDED FOR USE AS A FLAME RETARDANT ARTICLE.**

**NOTE:** Square yard weights are nominal and may vary +/- 10%  
 © Polytuf is a registered trademark. U.S. Pat. #4456122 Form WU-BAR4/06